

D*K*
EXPLOSION-PROOF
SOLENOID OPERATED
DIRECTIONAL CONTROL VALVES
in compliance with ATEX 94/9/EC

DS3K*	ISO 4401-03 (CETOP 03)
DL5BK*	ISO 4401-05 (CETOP 05)
DSP5K*	CETOP P05
DSP5RK*	ISO 4401-05 (CETOP R05)
DSP7K*	ISO 4401-07 (CETOP 07)
DSP8K*	ISO 4401-08 (CETOP 08)
DSP10K*	ISO 4401-10 (CETOP 10)

OPERATING PRINCIPLE

Type examination certificate number: CEC 13 ATEX 030-REV.2

- The direct operated directional valves are available in ISO 4401-03 (CETOP 03) and ISO 4401-05 (CETOP 05) size; available pilot operated sizes are: CETOP P05, ISO 4401-05 (CETOP R05), ISO 4401-07 (CETOP 07), ISO 4401-08 (CETOP 08) and ISO 4401-10 (CETOP 10).
- They are compliant with ATEX 94/9/EC standards and they are suitable for the use in potentially explosive atmospheres, that fall within the ATEX II 2GD (temperature class T4 or T5) or I M2, for mines. See par. 4 for ATEX classification, operating temperatures and electrical characteristics.
- The statement of conformity to the up-mentioned standards is always supplied with the valve.
- A low temperature version (up to - 40 °C) is available also.
- DS3K* and DL5BK* valves are supplied with a zinc-nickel finishing surface treatment that ensures a salt spray resistance up to 600 h; for DSP*K* valves, this treatment is available upon request.

PERFORMANCES

(working with mineral oil of viscosity of 36 cSt at 50°C)

		DS3K*	DL5BK*	DSP5K* DSP5RK*	DSP7K*	DSP8K*	DSP10K*	
Maximum operating pressure P - A - B ports	bar	350	320	320	350	350	350	
		T port	210	210	see operating limits at paragraph 7.2			
Maximum flow from P port to A - B - T	l/min	80	125	150	300	600	1100	
Operating temperatures (ambient and fluid)	°C	see paragraph 4.5						
Fluid viscosity range	cSt	10 ÷ 400						
Fluid contamination degree		According to ISO 4406:1999 class 20/18/15						
Recommended viscosity	cSt	25						
Mass	single solenoid valve double solenoid valve	kg	1,8	2,7	6,8	8,6	15,5	52
			2,8	3,8	7,8	9,6	16,5	53

1 - IDENTIFICATION OF DIRECT OPERATED SOLENOID VALVES

1.1 - Identification code

D

-

/ 10

-

K9

/

Direct operated solenoid valve

Size: _____

S3 = ISO 4401-03 (CETOP 03)
L5B = ISO 4401-05 (CETOP 05)

Explosion-proof version: _____

Protection type of the coil: "d"

KD2 = classified as ATEX II 2GD for gas or for dust
KDM2 = classified as ATEX I M2, for mines

Spool type (see par. 1.2) _____

S* TA TB RK
SA* TA02 TB02
SB* TA23 TB23

Series No.: _____
(the overall and mounting dimensions do not change from 10 to 19)

Seals: _____

For temperature range -20 / +80 °C
N = NBR seals for mineral oil (standard)
V = FPM seals for special fluids

For temperature range -40 / +80 °C
NL = seal for low temperatures (for mineral oil)

Power supply _____

D12 = 12 V
D24 = 24 V
D48 = 48 V
D110 = 110 V
R120 = 120 V
R240 = 240 V

Option: **/T5**
version in T5 temperature class.
See at par. 4.5
Omit if not required.

Manual override:
CM = boot protected
standard for both N and V seals
not available for NL seals
CB = blind ring nut
standard for NL seals
available upon request for both N and V seals
CH = lever manual override.
Not available for DLB5K*
Dimensions for CB and CH at par. 16

Connection type for cable gland
upper connection:
T01 = M20x1.5 - ISO 261
T02 = Gk 1/2 - UNI EN 10226-2
T03 = 1/2" NPT - ANSI B1.20.1 (ex ANSI B2.1)

side connection:
S01 = M20x1.5 - ISO 261
S02 = Gk 1/2 - UNI EN 10226-2
S03 = 1/2" NPT - ANSI B1.20.1 (ex ANSI B2.1)
S04 = M16x1.5 - ISO 261

Coil electrical connection: by terminal block

NOTE: the zinc-nickel standard finishing surface treatment is suitable to ensure a salt spray resistance up to 600 h (test operated according to UNI EN ISO 9227 standards and test evaluation operated according to UNI EN ISO 10289 standards)

1.2 - Available spools

Version S*:
2 solenoids - 3 positions
with spring centering

S1

S2

S3

S4

S9

Version SA*:
1 solenoid side A
2 positions (central + external)
with spring centering

SA1

SA2

SA3

SA4

SA9

Version SB*:
1 solenoid side B
2 positions (central + external)
with spring centering

SB1

SB2

SB3

SB4

SB9

Version RK:
2 solenoids - 2 positions
with mechanical detent

RK

Version TA:
1 solenoid side A
2 external positions
with return spring

TA

TA02

TA23

Version TB:
1 solenoid side B
2 external positions
with return spring

TB

TB02

TB23

NOTE: TA02/TB02 spools are not available for RAC solenoid valves.

2 - CHARACTERISTIC CURVES AND PERFORMANCES OF DIRECT OPERATED SOLENOID VALVES
2.1 - Pressure drops Δp -Q

(with mineral oil of viscosity of 36 cSt at 50°C)

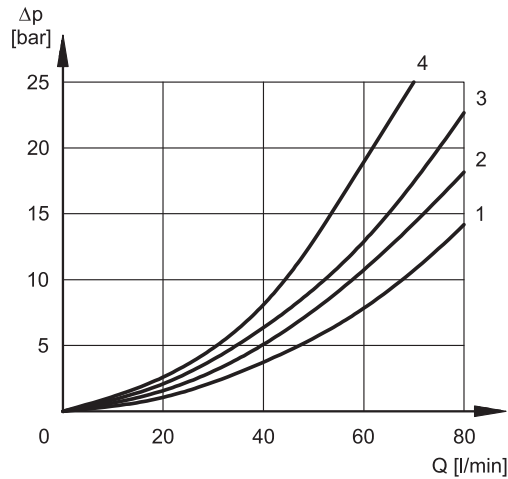
DS3K*
ENERGIZED VALVE

SPOOL	FLOW DIRECTION			
	P→A	P→B	A→T	B→T
	CURVES ON GRAPH			
S1, SA1, SB2	2	2	3	3
S2, SA2, SB2	1	1	3	3
S3, SA3, SB3	3	3	1	1
S4, SA4, SB4	4	4	4	4
S9, SA9, SB9	2	2	3	3
TA, TB	3	3	3	3
TA02, TB02	2	2	2	2
TA23, TB23	3	3	-	-
RK	2	2	2	2

DE-ENERGIZED VALVE

SPOOL	FLOW DIRECTION				
	P→A	P→B	A→T	B→T	P→T
	CURVES ON GRAPH				
S2, SA2, SB2	-	-	-	-	2
S3, SA3, SB3	-	-	3	3	-
S4, SA4, SB4	-	-	-	-	3

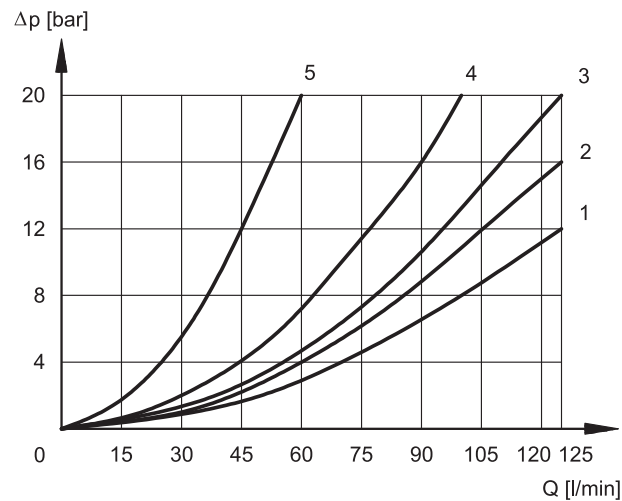
DL5BK*
ENERGIZED VALVE

SPOOL	FLOW DIRECTIONS			
	P→A	P→B	A→T	B→T
	CURVES ON GRAPHS			
S1	1	1	2	2
S2	1	1	1	1
S3	1	1	1	1
S4	4	4	4	4
S9	1	1	1	1
RK	2	2	2	2
TA	2	2	3	3
TA02	2	2	1	1
TA23	3	3	-	-

DE-ENERGIZED VALVE

SPOOL	FLOW DIRECTIONS		
	A→T	B→T	P→T
	CURVES ON GRAPHS		
S2	-	-	1
S3	5	5	-
S4	-	-	1

2.2 - Performance limits

The curves define the flow rate operating fields according to the valve pressure of the different versions. The values have been obtained according to ISO 6403 norm with solenoids at rated temperature and supplied with voltage equal to 90% of the nominal voltage, with mineral oil with viscosity 36 cSt, temperature 50 °C and filtration according to ISO 4406:1999 class 18/16/13.

The operating limits can be considerably reduced if a 4-way valve is used as 3-way valve with port A or B plugged or without flow.

DS3K*

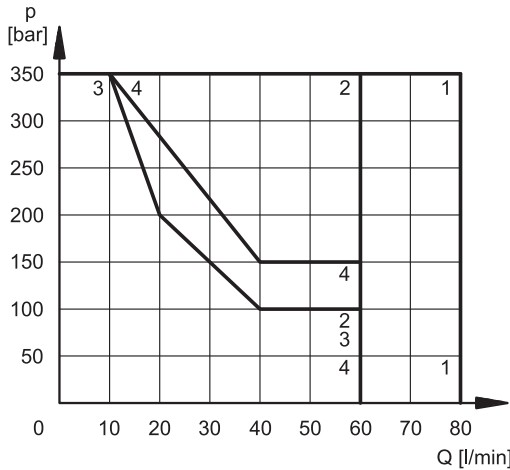

DC SOLENOID VALVE

SPOOL	CURVE	
	P→A	P→B
S1,SA1,SB1	1	1
S2, SA2, SB2	2	2
S3, SA3, SB3	3	3
S4, SA4, SB4	2	2
S9, SA9, SB9	1	1
TA, TB	1	1
TA02, TB02	4	4
TA23, TB23	4	4
RK	1	1

RAC SOLENOID VALVE

SPOOL	CURVE	
	P→A	P→B
S1,SA1,SB1	1	1
S2, SA2, SB2	2	2
S3, SA3, SB3	3	3
S4, SA4, SB4	4	4
S9, SA9, SB9	1	1
TA, TB	1	1
TA02 *, TB02 *	X	X
TA23, TB23	4	4
RK	1	1

* not available

DL5BK*

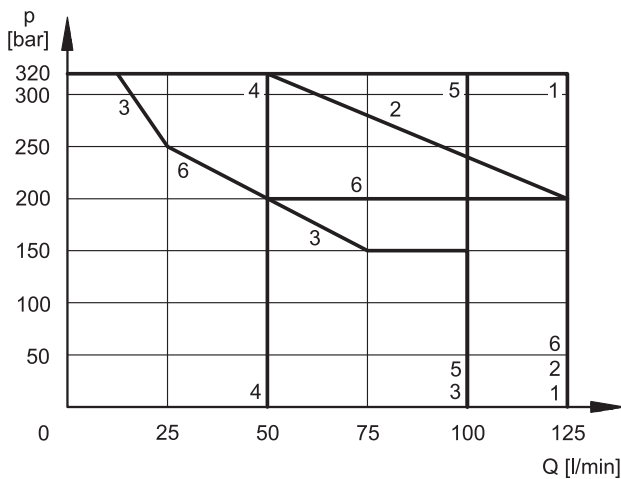

SPOOL	CURVE
S1, S2, RK	1
TA02	2
S3	3
S4	4
TA, TA23	5
S9	6

2.3 - Switching times

The indicated values are obtained according to ISO 6403 standard, with mineral oil viscosity 36 cSt at 50°C.

TIMES [ms]	DS3K*		DL5BK*	
	ENERGIZING	DE-ENERGIZING	ENERGIZING	DE-ENERGIZING
DC	60	40	70 + 100	15 + 20
RAC	60	140	70 + 100	140

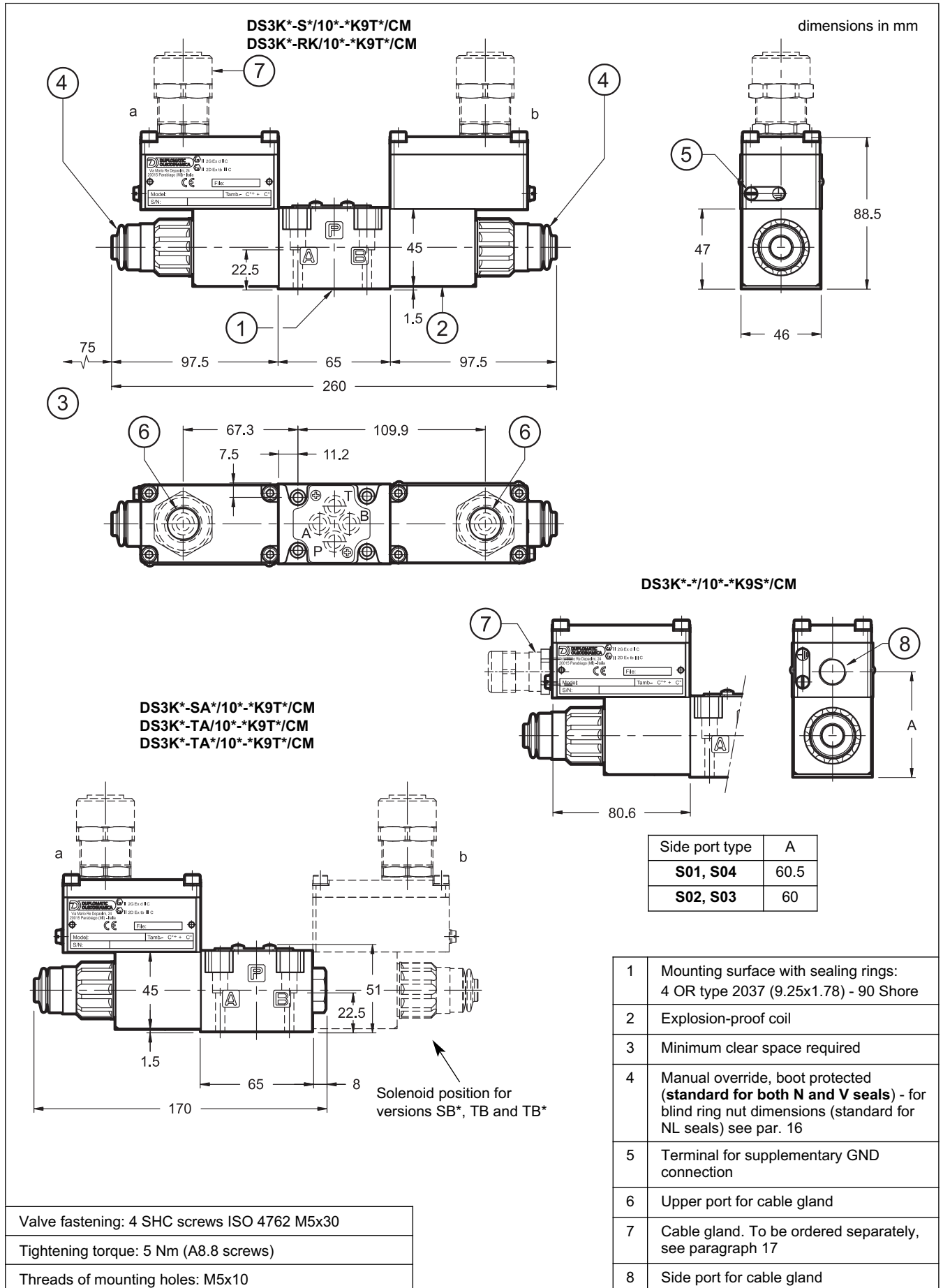
3 - OVERALL AND MOUNTING DIMENSIONS OF DIRECT OPERATED VALVES

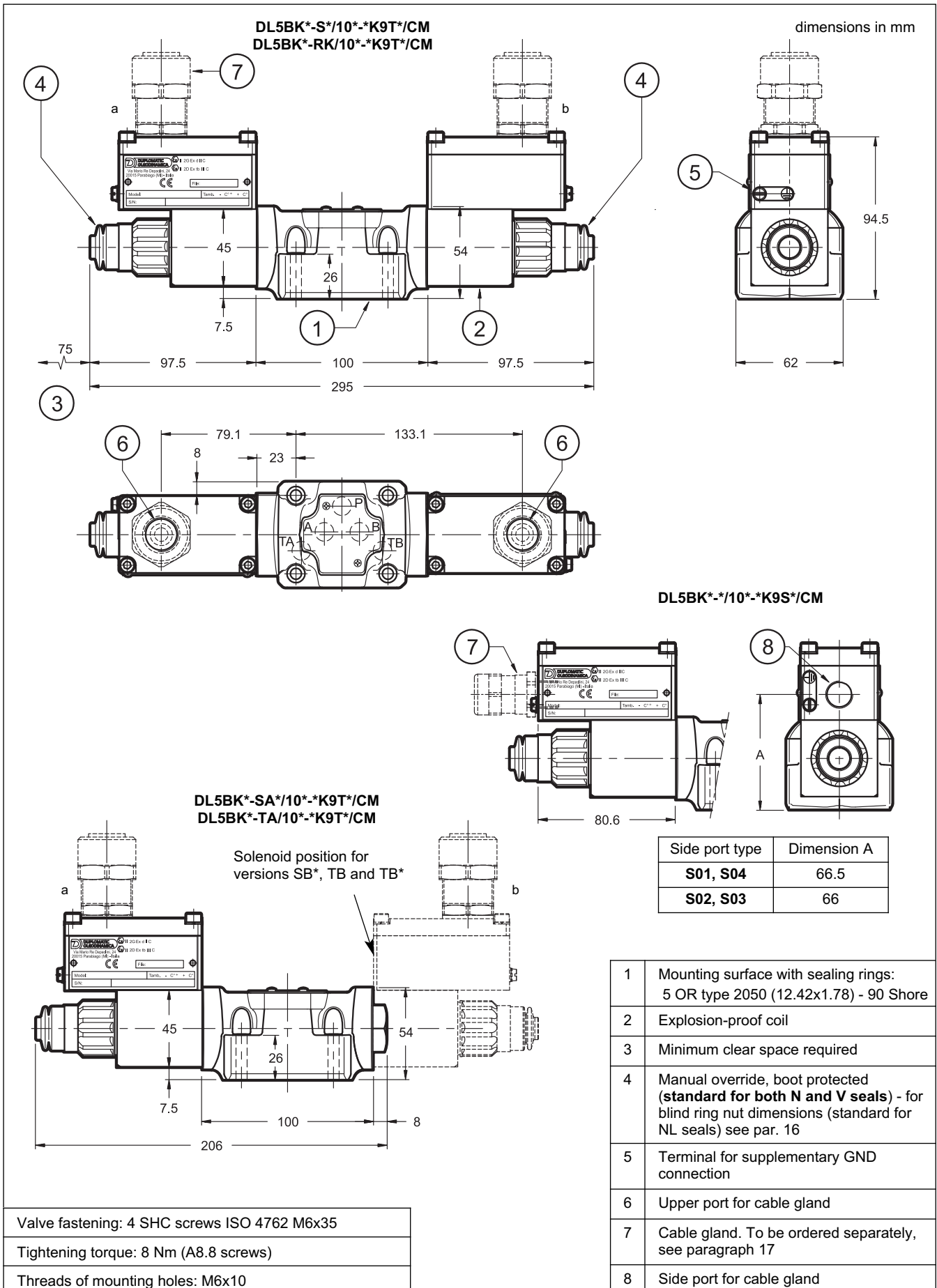

4 - ATEX CLASSIFICATION, OPERATING TEMPERATURES AND ELECTRICAL CHARACTERISTICS

Diplomatic certificates the combination valve-coil for the valves suitable for application and installation in potentially explosive atmospheres, according to ATEX directive prescriptions; **the supply always includes the declaration of conformity to the directive and the operating and maintenance manual, that contains all the information needed for a correct use of the valve in potentially explosive environments.**

Coils assembled on these valves have been separately certified according to ATEX directive and so they are suitable for use in potentially explosive atmospheres.

4.1 - ATEX classification for valves

The valves are suitable for applications and installations in potentially explosive atmospheres that fall within:

ATEX II 2G ATEX II 2D	*KD2	intended for use in areas in which explosive atmospheres caused by gases, vapours, mists or air/dust mixtures are likely to occur occasionally.
ATEX I M2	*KDM2	intended for use in underground parts of mines as well as those parts of surface installations of such mines likely to be endangered by firedamp and/or combustible dust. This equipment is intended to be de-energised in the event of an explosive atmosphere.

4.2 - ATEX marking for valves

valve code		N and V seals	NL seals
*KD2	for gas	II 2G IIC T4 Gb (-20°C Ta +80°C)	II 2G IIC T4 Gb (-40°C Ta +80°C)
	for dusts	II 2D IIIC T154°C Db IP66/IP68 (-20°C Ta +80°C)	II 2D IIIC T154°C Db IP66/IP68 (-40°C Ta +80°C)
*KD2 /T5	for gas	II 2G IIC T5 Gb (-20°C Ta +55°C)	II 2G IIC T5 Gb (-40°C Ta +55°C)
	for dusts	II 2D IIIC T129°C Db IP66/IP68 (-20°C Ta +55°C)	II 2D IIIC T129°C Db IP66/IP68 (-40°C Ta +55°C)
*KDM2	mining	I M2 I T150°C Mb IP66/68 (-20°C Ta +75°C)	I M2 I T150°C Mb IP66/68 (-40°C Ta +75°C)

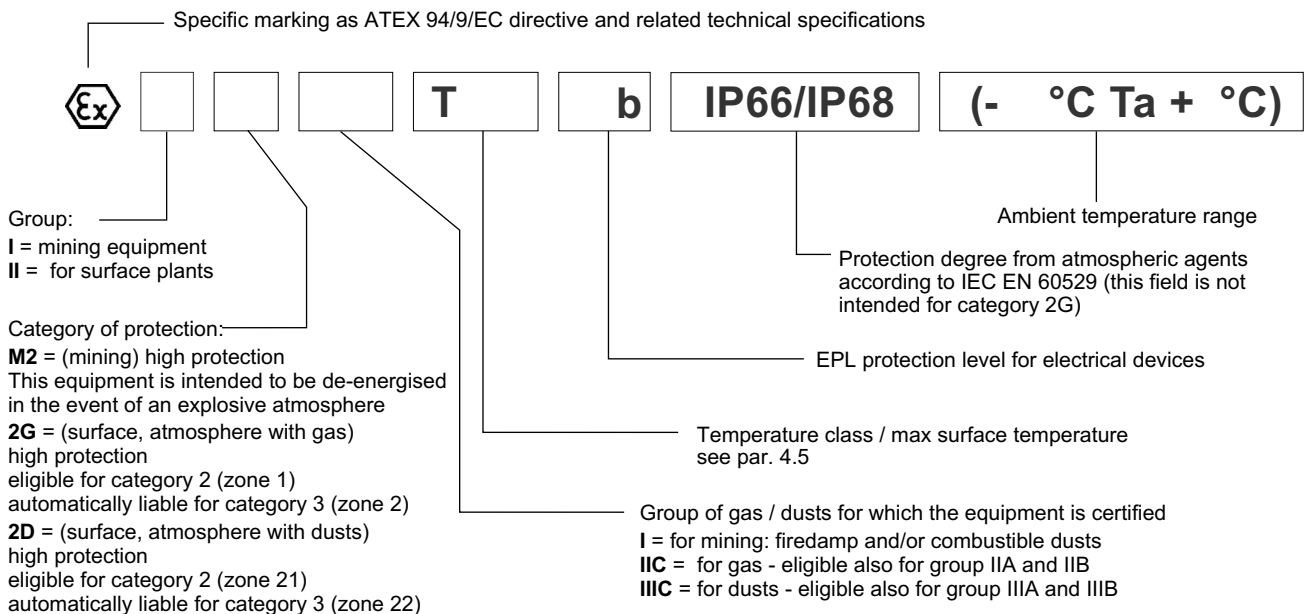

4.3 - ATEX classification of the coils

The coil of the explosion-proof valves is identified with its own tag, which carries the relative ATEX marking. **The mechanical construction of the coil housing is made in order to ensure its resistance to possible internal explosion and to avoid any explosion propagation to the outside environment, matching an “Ex d” type protection (explosion-proof coil).**

Moreover, the solenoid is designed to maintain its surface temperature below the limits specified to the relevant class.

The R* coils (for alternating current supply) contain a built-in rectifier bridge.

4.4 - ATEX marking on coils

for valve type *KD2	for gas	II 2G Ex d IIC T4 Gb (-40°C Ta +80°C)
	for dusts	II 2D Ex tb IIIC T154°C Db IP66/IP68 (-40°C Ta +80°C)
for valve type *KD2 /T5	for gas	II 2G Ex d IIC T5 Gb (-40°C Ta +55°C)
	for dusts	II 2D Ex tb IIIC T129°C Db IP66/IP68 (-40°C Ta +55°C)
for valve type *KDM2	mining	I M2 Ex d I T150°C Mb IP66/IP68 (-40°C Ta +75°C)

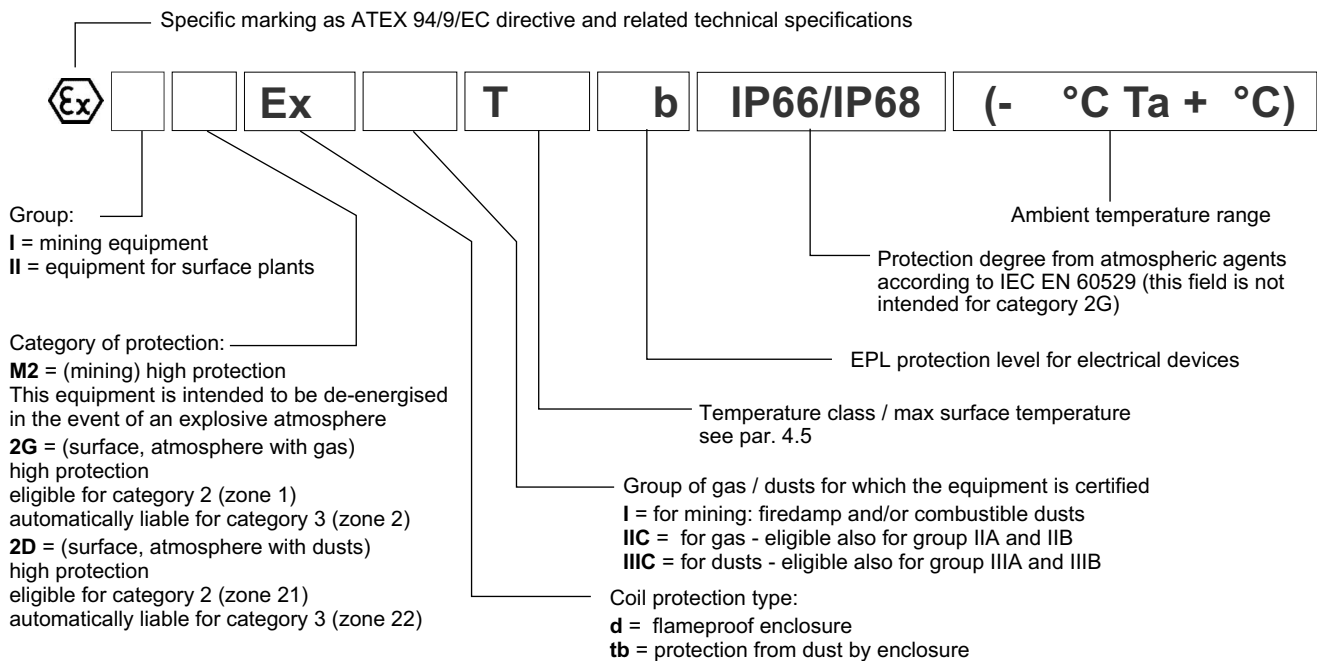

4.5 - Operating temperatures

These valves are classified according to their maximum surface temperature (EN 13463-1), which must be lower than the ignition temperature of the gases, vapors and dusts for which the area in which they will be used is classified.

The valves in group II can also be used for less limiting temperature classes (surface temperature allowed higher).

		temperature range	N and V seals	NL seals	Temperature class	eligible also for
ATEX II 2G ATEX II 2D	*KD2	of ambient	-20 / +80 °C	-40 / +80 °C	T4 (gas) T154°C (dusts)	T3, T2, T1 T200°C and higher
		of fluid				
	*KD2 /T5	of ambient	-20 / +55 °C	-40 / +55 °C	T5 (gas) T129°C (dusts)	T4, T3, T2, T1 T135°C and higher
		of fluid	-20 / +60 °C	-40 / +60 °C		
ATEX I M2	*KDM2	of ambient	-20 / +75 °C	-40 / +75 °C	T150°C	-
		of fluid				

4.6 - Electrical characteristics (values ± 5%)

Coil type	Nominal voltage [V]	Resistance at 20°C [Ω]	Current consumpt. [A]	Power consumpt. [W]
D12	12	7,2	1,7	20
D24	24	28,7	0,83	20
D48	48	115	0,42	20
D110	110	549	0,2	22

Coil type (NOTE)	Nominal voltage [V]	Freq. [Hz]	Resistance at 20°C [Ω]	Current consumpt. [A]	Power consumpt. [VA]
R120	110V-50Hz 120V-60Hz	50/60	489,6	0,19	21
				0,21	25
R240	230V-50Hz 240V-60Hz	50/60	2067,7	0,098	22,5
				0,1	24

VOLTAGE SUPPLY FLUCTUATION (ripple included)	± 10% Vnom
MAX SWITCH ON FREQUENCY DS3K*, DL5BK* DSP5K*, DSP5RK* DSP7K* DSP8K* DSP10K*	8.000 ins/hr 6.000 ins/hr 6.000 ins/hr 4.000 ins/hr 3.000 ins/hr
DUTY CYCLE	100%
EXPLOSION-PROOF VERSION	According to ATEX 94/9/EC
ELECTROMAGNETIC COMPATIBILITY (EMC)	According to 2004/108/EC
CLASS OF PROTECTION: Atmospheric agents Coil insulation (VDE 0580)	IP66 / IP68 class H

NOTE: type R* coils are for alternating current supply for both 50 or 60 Hz. For R* coils the resistance can not be measured in the usual way because of the presence of diodes bridge inside the coil.

5 - ELECTRICAL CONNECTION
5.1 - Wiring

In order to realise the electrical connection of the coil, it is necessary to access the terminal block (1) unscrewing the 4 screws (2) that fasten the cover (3) with the box (4) that contains the terminal block.

The electrical connection is polarity-independent.

By doing electrical connection it is important to connect also the grounding point (5) in the terminal block box (M4 screws), through suitable conductors with the general grounding line of the system.

On the external body of the coil there is a grounding point (6) (M4 screw) that allow to ensure equipotentiality between the valve and the general grounding line of the system; connecting this point the regulation of the EN 13463-1 standard, that impose to verify the equipotentiality of the elements included in a potentially explosive environment (the maximum resistance between the elements must be 100 Ω), is guaranteed.

At the end of the electrical wiring, it is necessary to reassemble the cover (3) on the box (4), checking the correct positioning of the seal located in the cover seat and fastening the 4 M5 screws with a torque of 4.9+6 Nm.

Electrical wiring must be done following the instructions of the rules in compliance with ATEX standards.

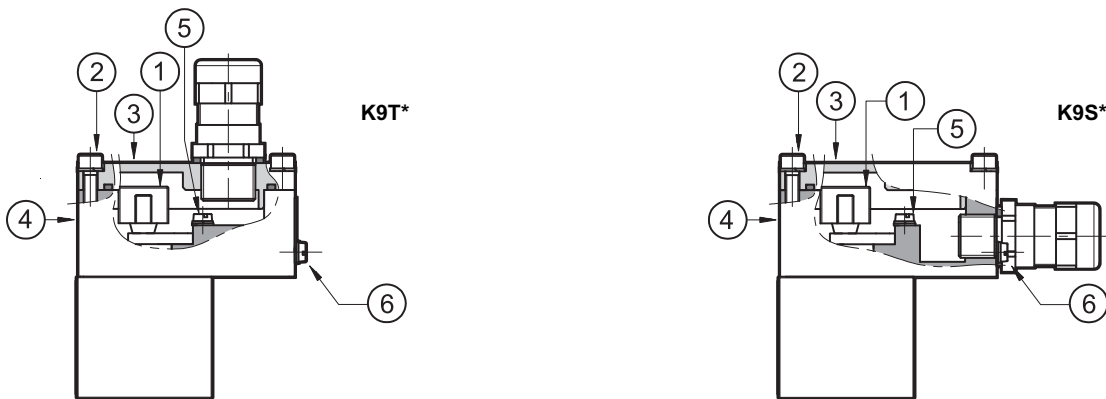

Characteristics of the cables connectable for wiring are indicated in the table below:

Function	Cable section
Operating voltage cables connection	max 2.5 mm ²
Connection for internal grounding point	max 2.5 mm ²
Connection for external equipotential grounding point	max 6 mm ²

Cables for wiring must be non-armoured cables, with external covering sheath and must be suitable for use in environments with temperatures from - 20 °C to +110 °C (for valves either with N or V seals) or from - 40 °C to +110 °C (for valves with NL seals).

Cable glands (which must be ordered separately, see paragraph 17) allow to use cables with external diameter between 8 and 10 mm.

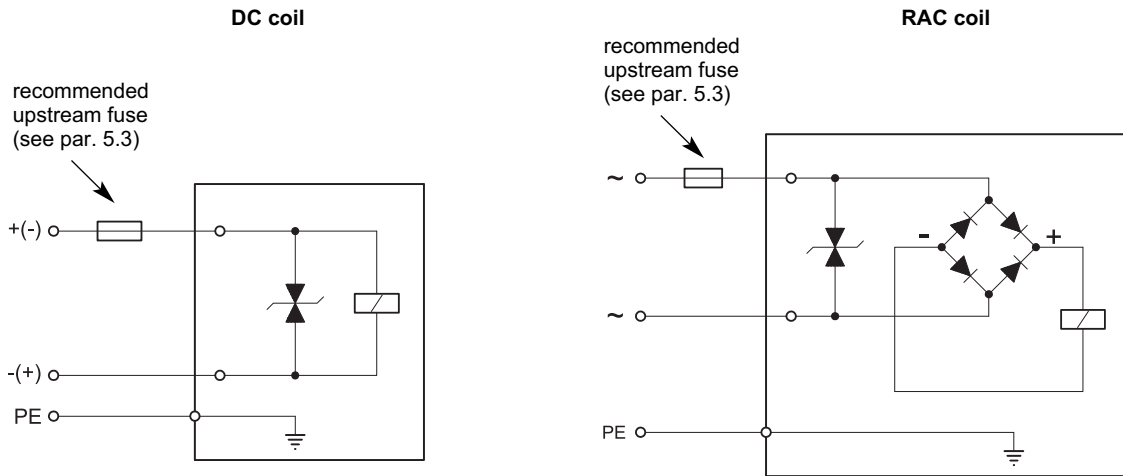
5.2 - Electrical diagrams

5.3 - Overcurrent fuse and switch-off voltage peak

Upstream of each valve, an appropriate fuse (max 3 x I_n according to IEC 60127) or a protective motor switch with short-circuit and thermal instantaneous tripping, as short-circuit protection, must be connected. The cut-off power of the fuse must correspond or exceed the short circuit current of the supply source. The fuse or the protective motor must be placed outside the dangerous area or they must be protected with an explosion-proof covering.

In order to safeguard the electronic device to which the valve is connected, there is a protection circuit in the coil, that reduces voltage peaks, which can occur when inductances are switched off.

The table shows the type of fuse recommended according to the nominal voltage of the valve and to the value of the voltage peaks reduction.

Coil type	Nominal voltage [V]	Rated current [A]	Recommended pre-fuse characteristics medium time-lag according to DIN 41571 [A]	Maximum voltage value upon switch off [V]	Suppressor circuit
D12	12	1,7	2,5	- 49	Transient voltage suppressor bidirectional
D24	24	0,83	1,25	- 49	
D48	48	0,42	0,6	- 81	
D110	110	0,2	0,3	- 309	
R120	120	0,21	0,3	- 3	
R240	240	0,1	0,15	- 3	

6 - IDENTIFICATION OF PILOT OPERATED SOLENOID VALVES DSP*K*

6.1 - Identification code

D	S	P	-	/ 10	-	/	/	K9	/				
----------	----------	----------	---	------	---	---	---	-----------	---	--	--	--	--

Pilot operated directional valve

Size: _____
5 = CETOP P05
5R = ISO 4401-05 (CETOP R05)
7 = ISO 4401-07 (CETOP 07)
8 = ISO 4401-08 (CETOP 08)
10 = ISO 4401-10 (CETOP 10)

Explosion-proof version: _____
 Protection type of the coil: "d"
KD2 = classified as ATEX II 2GD for gas or for dust
KDM2 = classified as ATEX I M2, for mines

Spool type (see par. 6.2) _____
S* **TA** **TB** **RK**
SA* **TA02** **TB02**
SB*

Series No.: (the overall and mounting dimensions remain unchanged from 10 to 19) _____

Seals: _____
 For temperature range -20 / +80 °C
N = NBR seals for mineral oil (standard)
V = FPM seals for special fluids
 For temperature range -40 / +80 °C
NL = seal for low temperatures (for mineral oil)

Piloting: _____
I = internal (not available for spools S2, S4, TA02, TB02, S*2 and S*4. If internal piloting should be necessary, choose piloting type C)
E = external
C = internal piloting with backpressure valve (available on DSP7 and DSP8)
Z = internal piloting with 30 bar fixed adjustment pressure reducing valve

Drainage: _____
I = Internal
E = External

Options: _____
C = main spool stroke control
D = main spool shifting speed control
P08 = Subplate with restrictor Ø0,8 on port P placed under the solenoid valve - for valves DSP5 - DSP5R - DSP7 - DSP8
P15 = subplate with restrictor Ø1,5 on port P placed under the solenoid valve - only for valves DSP10

Option: surface treatment not standard. Omit if not required (see NOTE)

Option: /T5 version in T5 temperature class. See at par. 4.5. Omit if not required.

Manual override:
CM = boot protected **standard for both N and V seals** not available for NL seals
CB = blind ring nut **standard for NL seals** available upon request for both N and V seals see dimensions at paragraph 16

Connection type for cable gland upper connection:
T01 = M20x1.5 - ISO 261
T02 = Gk 1/2 - UNI EN 10226-2
T03 = 1/2" NPT - ANSI B1.20.1 (ex ANSI B2.1)
 side connection:
S01 = M20x1.5 - ISO 261
S02 = Gk 1/2 - UNI EN 10226-2
S03 = 1/2" NPT - ANSI B1.20.1 (ex ANSI B2.1)
S04 = M16x1.5 - ISO 261

Coil electrical connection: by terminal block

Power supply
D12 = 12 V
D24 = 24 V
D48 = 48 V
D110 = 110 V
R120 = 120 V
R240 = 240 V
 } direct current (DC)
 } rectified current (RAC)

A version suitable for an operating pressure value of **420 bar** on ports P - A - B is available upon request, except for DSP5K* / DSP5RK* and DSP10K* valves. On this version, the maximum pressure value on port T with external drainage and the piloting pressure are equal to 350 bar. The maximum pressure on port T with internal drainage is 210 bar.

Add the letter **H** to request this version (ex. DSP7HK*).

NOTE: the valves are supplied with standard surface treatment of phosphating black for the main body and zinc-nickel for the pilot body. Upon request we can supply these valves with full zinc-nickel surface treatment, suitable to ensure a salt spray resistance up to 600 h (test operated according to UNI EN ISO 9227 standards and test evaluation operated according to UNI EN ISO 10289 standards).

For full zinc-nickel surface treatment add **/W7** at the end of the identification code.

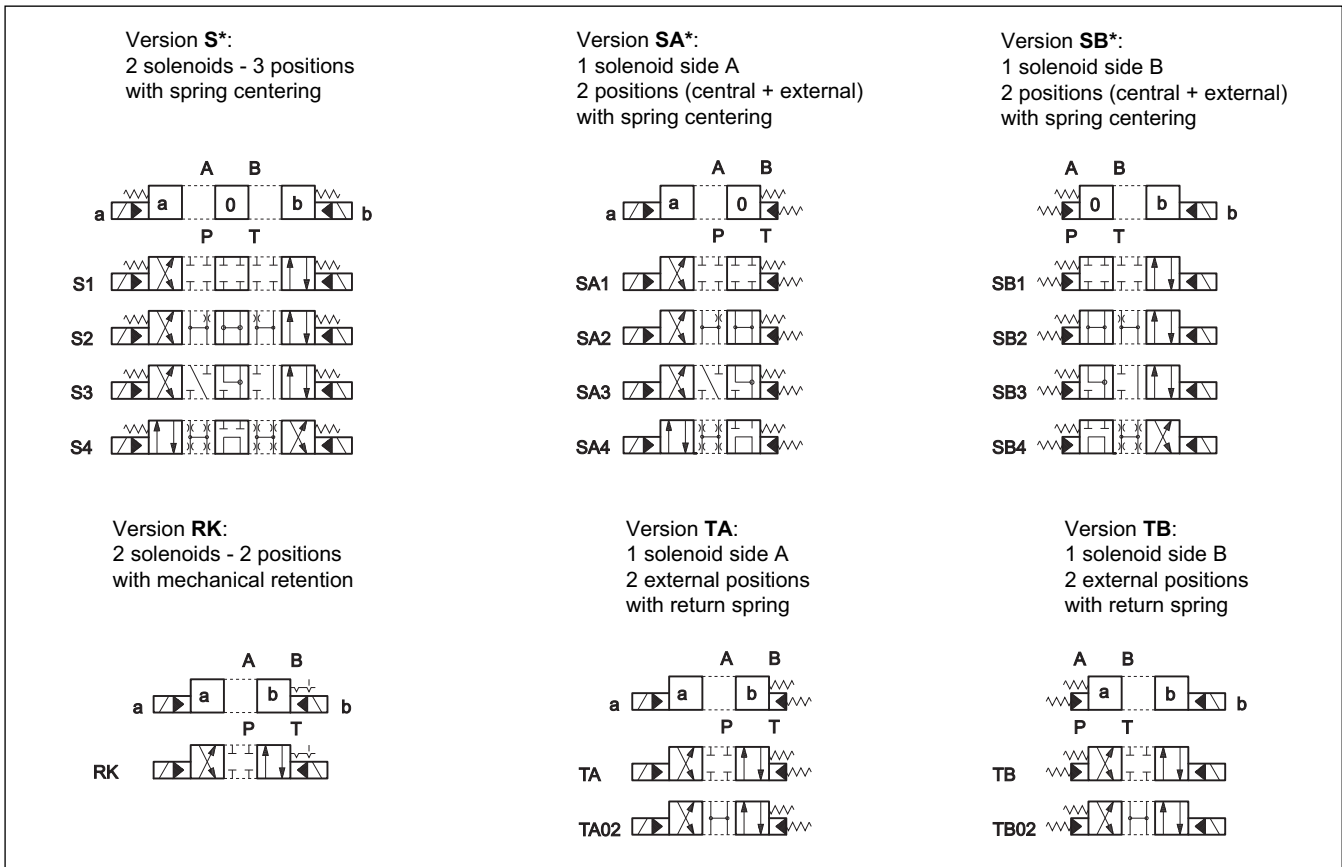
6.2 - Spool types

7 - CHARACTERISTIC CURVES AND PERFORMANCES OF PILOT OPERATED SOLENOID VALVES
7.1 - Pressure drops Δp -Q

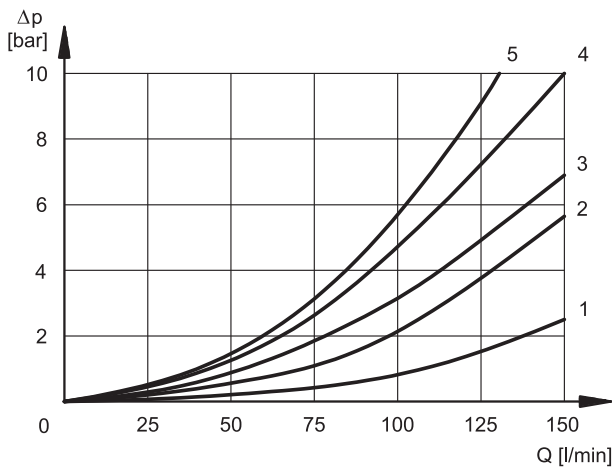
(values obtained with viscosity 36 cSt at 50 °C)

DSP5K* - DSP5RK*
ENERGIZED POSITION

SPOOL	FLOW DIRECTION			
	P→A	P→B	A→T	B→T
	CURVES ON GRAPH			
S1, SA1, SB1	4	4	1	1
S2, SA2, SB2	3	3	1	2
S3, SA3, SB3	4	4	1	1
S4, SA4, SB4	5	5	2	3
TA, TB	4	4	1	1
TA02, TB02	3	3	1	1
RK	4	4	1	1

DE-ENERGIZED POSITION

SPOOL	FLOW DIRECTION				
	P→A	P→B	A→T	B→T	P→T
	CURVES ON GRAPH				
S2, SA2, SB2	-	-	-	-	5
S3, SA3, SB3	-	-	4	4	-
S4, SA4, SB4	-	-	-	-	5



DSP7K*

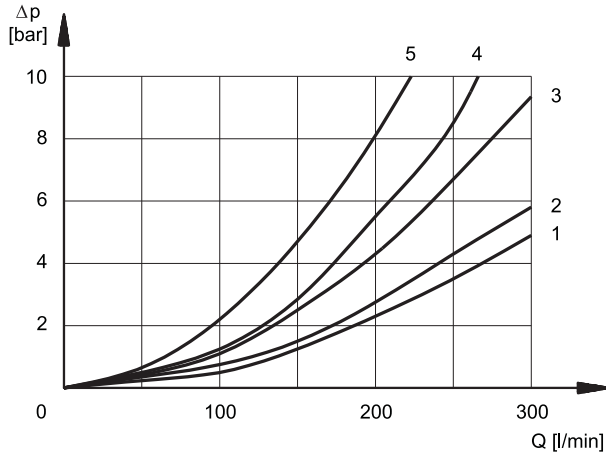

ENERGIZED POSITION

SPOOL	FLOW DIRECTION			
	P→A	P→B	A→T	B→T
	CURVES ON GRAPH			
S1, SA1, SB1	1	1	3	4
S2, SA2, SB2	1	1	4	4
S3, SA3, SB3	1	1	4	4
S4, SA4, SB4	2	2	4	5
TA, TB	1	1	3	4
TA02, TB02	1	1	4	4
RK	1	1	3	4

DE-ENERGIZED POSITION

SPOOL	FLOW DIRECTION				
	P→A	P→B	A→T	B→T	P→T
	CURVES ON GRAPH				
S2, SA2, SB2	-	-	-	-	2
S3, SA3, SB3	-	-	4	4	-
S4, SA4, SB4	-	-	-	-	4

DSP8K*

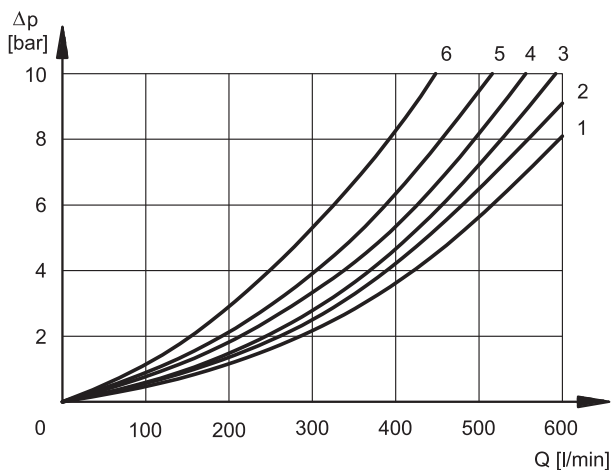

ENERGIZED POSITION

SPOOL	FLOW DIRECTION			
	P→A	P→B	A→T	B→T
	CURVES ON GRAPH			
S1, SA1, SB1	2	2	3	3
S2, SA2, SB2	1	1	2	1
S3, SA3, SB3	2	2	2	1
S4, SA4, SB4	4	4	3	5
TA, TB	2	2	3	3
TA02, TB02	2	2	3	3
RK	2	2	3	3

DE-ENERGIZED POSITION

SPOOL	FLOW DIRECTION				
	P→A	P→B	A→T	B→T	P→T
	CURVES ON GRAPH				
S2, SA2, SB2	-	-	-	-	4
S3, SA3, SB3	-	-	4	4	-
S4, SA4, SB4	-	-	-	-	6

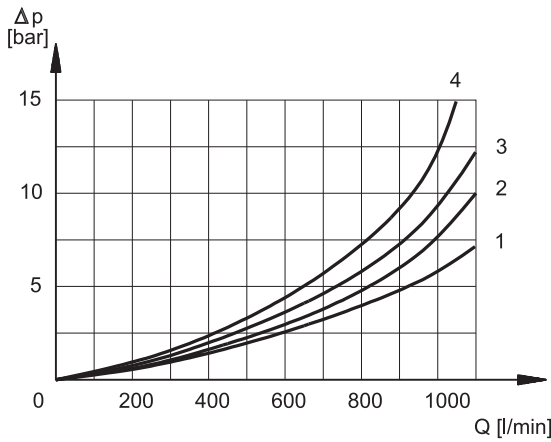
DSP10K*
ENERGIZED POSITION

SPOOL	FLOW DIRECTION			
	P→A	P→B	A→T	B→T
	CURVES ON GRAPH			
S1, SA1, SB1	1	1	1	1
S2, SA2, SB2	2	2	2	2
S3, SA3, SB3	1	1	4	4
S4, SA4, SB4	2	2	2	2
TA, TB	1	1	1	1
TA02, TB02	1	1	1	1
RK	1	1	1	1

DE-ENERGIZED POSITION

SPOOL	FLOW DIRECTION				
	P→A	P→B	A→T	B→T	P→T
	CURVES ON GRAPH				
S2, SA2, SB2	-	-	-	-	3
S3, SA3, SB3	-	-	4	4	-
S4, SA4, SB4	-	-	-	-	4

7.2 - Performance limits of pilot operated valves

PRESSURES	DSP5K* DSP5RK*	DSP7K*	DSP8K*	DSP10K*
Max pressure in P, A, B ports	320	350	350	350
Max pressure in T or Y line	210	210	210	210
Max pressure in Y line	210	210	210	210
Min piloting pressure NOTE 1	5 ÷ 10	5 ÷ 12	7 ÷ 14	6 ÷ 12
Max piloting pressure NOTE 2	210	210	210	280

NOTE 1: minimum piloting pressure can be the lower range value at low flows rates, but with higher flow rates the higher value is needed.

NOTE 2: if the valve operates with higher pressures it is necessary to use the version with external pilot and reduced pressure. Otherwise, the valve with internal pilot and pressure reducing valve with 30 bar fixed adjustment can be ordered.

Add the letter **Z** to the identification code to order this option (see par. 6.1). Consider that, by adding the pressure reducing valve, the overall dimensions increase 40 mm in height.

MAXIMUM FLOW RATES	DSP5K* DSP5RK*	DSP7K*	DSP8K*	DSP10K*					
Spool type	PRESSURES								
	at 210 bar	at 320 bar	at 210 bar	at 350 bar	at 210 bar	at 350 bar	at 210 bar	at 350 bar	
S4 - SA4 - SB4	120	100	200	150	500	450	750 (NOTE)	600 (NOTE)	
Other spools	150	120	300	300	600	500	900	700	

NOTE: for the DSP10K* valve these values are the same even for S2 - SA2 - SB2 spools.

7.3 - Switching times

The values indicated refer to a solenoid valve working with piloting pressure of 100 bar, with mineral oil at a temperature of 50°C, at viscosity of 36 cSt and with PA and BT connections.

The energizing and de-energizing times are obtained at the pressure variation which occurs on the lines.

TIMES (± 10%) [ms]	ENERGIZING		DE- ENERGIZING	
	DC - RAC	DC	DC	RAC
DSP5K* - DSP5RK*	70		60	160
DSP7K*	80		70	170
DSP8K*	90		70	170
DSP10K*	120		90	190

8 - PILOTING AND DRAINAGE

DSP*K* valves are available with piloting and drainage, both internal and external.

The version with external drainage allows for a higher back pressure on the outlet.

TYPE OF VALVE		Plug assembly	
		X	Y
IE	INTERNAL PILOT AND EXTERNAL DRAIN	NO	YES
II	INTERNAL PILOT AND INTERNAL DRAIN	NO	NO
EE	EXTERNAL PILOT AND EXTERNAL DRAIN	YES	YES
EI	EXTERNAL PILOT AND INTERNAL DRAIN	YES	NO

DSP5K*
DSP5RK*

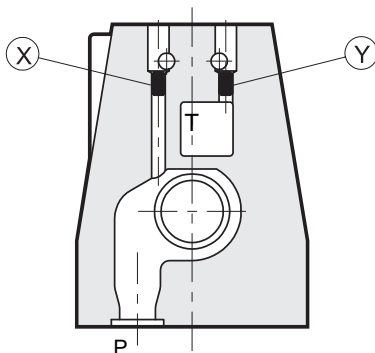

X: plug M5x6 for external pilot
Y: plug M5x6 for external drain

DSP7K*

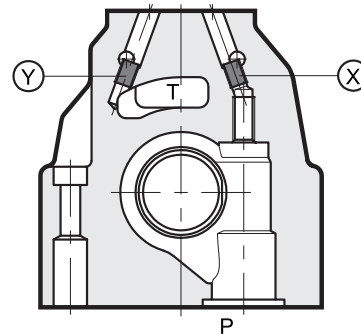

X: plug M6x8 for external pilot
Y: plug M6x8 for external drain

DSP8K*

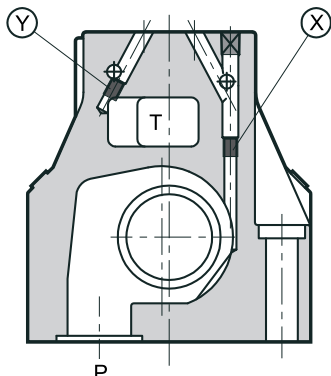

X: plug M6x8 for external pilot
Y: plug M6x8 for external drain

DSP10K*

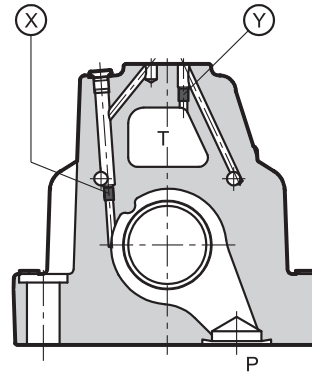

X: plug M6x8 for external pilot
Y: plug M6x8 for external drain

8.1 - Backpressure valve incorporated on line P (C option)

DSP7K* and DSP8K* valves are available upon request with backpressure valve incorporated on line P. This is necessary to obtain the piloting pressure when the control valve, in rest position, has the line P connected to the T port (spools S2 - S4 - S*2 - S*4 - TA02 - TB02). The cracking pressure is of 5 bar with a minimum flow rate of 15 l/min.

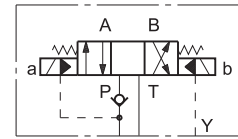

In the C version the piloting is always internal.

NOTE: the backpressure valve can't be used as check valve because it doesn't assure the seal.

Add **C** to the identification code for this request (see paragraph 6.1).

For DSP7K* only, the backpressure valve can be also delivered separately and it can be easily mounted on line P of the main control valve. Ask for code **0266577** to order the backpressure valve.

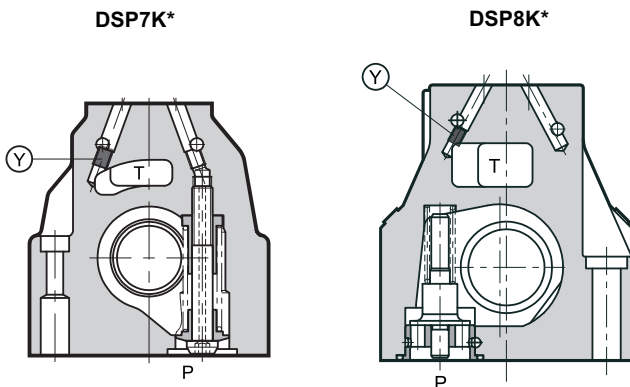

pilot always internal
Y: plug M6x8 for external drain

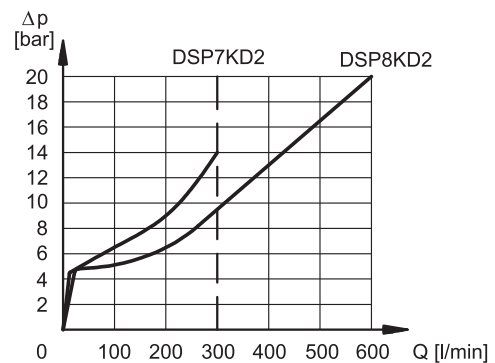

The curve refers to the pressure drop (body part only) with backpressure valve energized to which the pressure drop of the reference spool must be added (see paragraph 7.1).

9 - OPTIONS

9.1 - Control of the main spool stroke: C

With the help of special side plugs, it is possible to introduce stroke controls in the heads of the piloted valve so as to vary the maximum spool clearance opening.

This solution allows control of the flow rate from the pump to the actuator and from the actuator to the outlet, obtaining a double adjustable control on the actuator.

Add the letter **C** to the identification code to request this device (see paragraph 6.1).

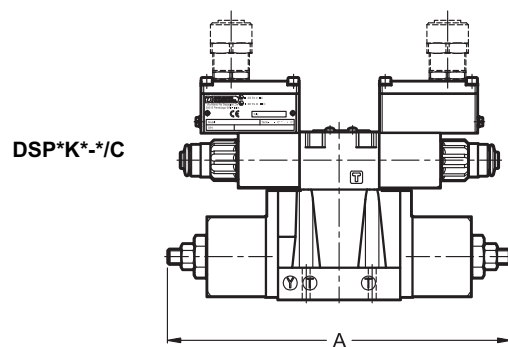

dimensions in mm

	DSP5K* DSP5RK*	DSP7K*	DSP8K*	DSP10K*
A	280	319	401.5	520

9.2 - Control of the main spool shifting speed: D

By placing a MERS type double flow control valve between the pilot solenoid valve and the main distributor, the piloted flow rate can be controlled and therefore the changeover smoothness can be varied.

Add the letter **D** to the identification code to request this device (see paragraph 6.1).

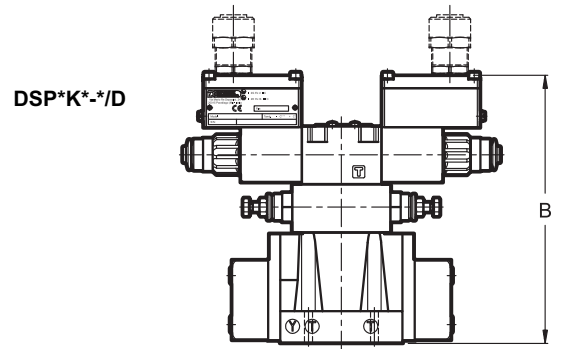

dimensions in mm

	DSP5K* DSP5RK*	DSP7K*	DSP8K*	DSP10K*
B	218.5	225.5	254.5	310.5

9.3 - Subplate with throttle on line P

It is possible to introduce a subplate with a restrictor on line P between the pilot solenoid valve and the main distributor.

restrictor $\varnothing 0.8$ for DSP5K*, DSP5RK*, DSP7K* e DSP8K*
 restrictor $\varnothing 1.5$ for DSP10K*:

To request include in the code (par. 6.1):

P08 for DSP5K*, DSP5RK*, DSP7K* and DSP8K*

P15 for DSP10K*

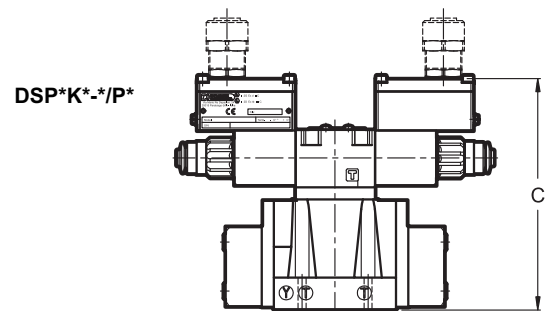

dimensions in mm

	DSP5K* DSP5RK*	DSP7K*	DSP8K*	DSP10K*
C	188.5	195.5	224.5	280.5

10 - DSP5K* AND DSP5RK* OVERALL AND MOUNTING DIMENSIONS

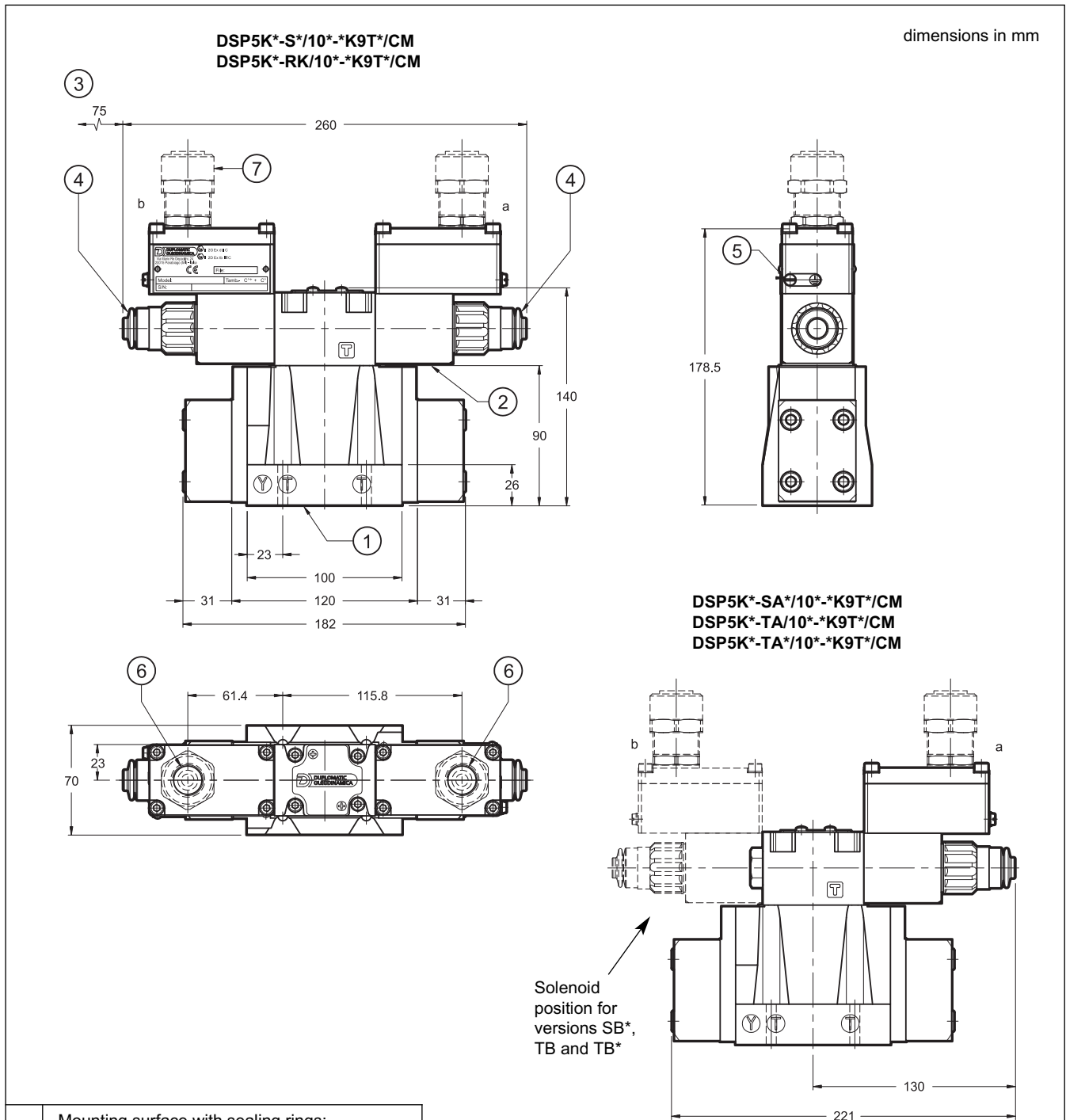

1	Mounting surface with sealing rings: 5 OR type 2050 (12.42x1.78) - 90 Shore 2 OR type 2037 (9.25x1.78) - 90 Shore
2	Explosion-proof coil
3	Minimum clear space required
4	Manual override, boot protected (standard for both N and V seals) - for blind ring nut dimensions (standard for NL seals) see par. 16
5	Terminal for supplementary GND connection
6	Upper port for cable gland
7	Cable gland. To be ordered separately, see paragraph 17

NOTE 1: for overall dimensions with Z option (fixed adjustment pressure reducing valve) consider an increase of 40 mm in height.
NOTE 2: for side port cable gland see paragraph 14.

Valve fastening: 4 SHC ISO 4762 screws M6x35
Tightening torque: 8 Nm (A8.8 screws) 12 Nm (A10.9 screws)
Threads of mounting holes: M6x10

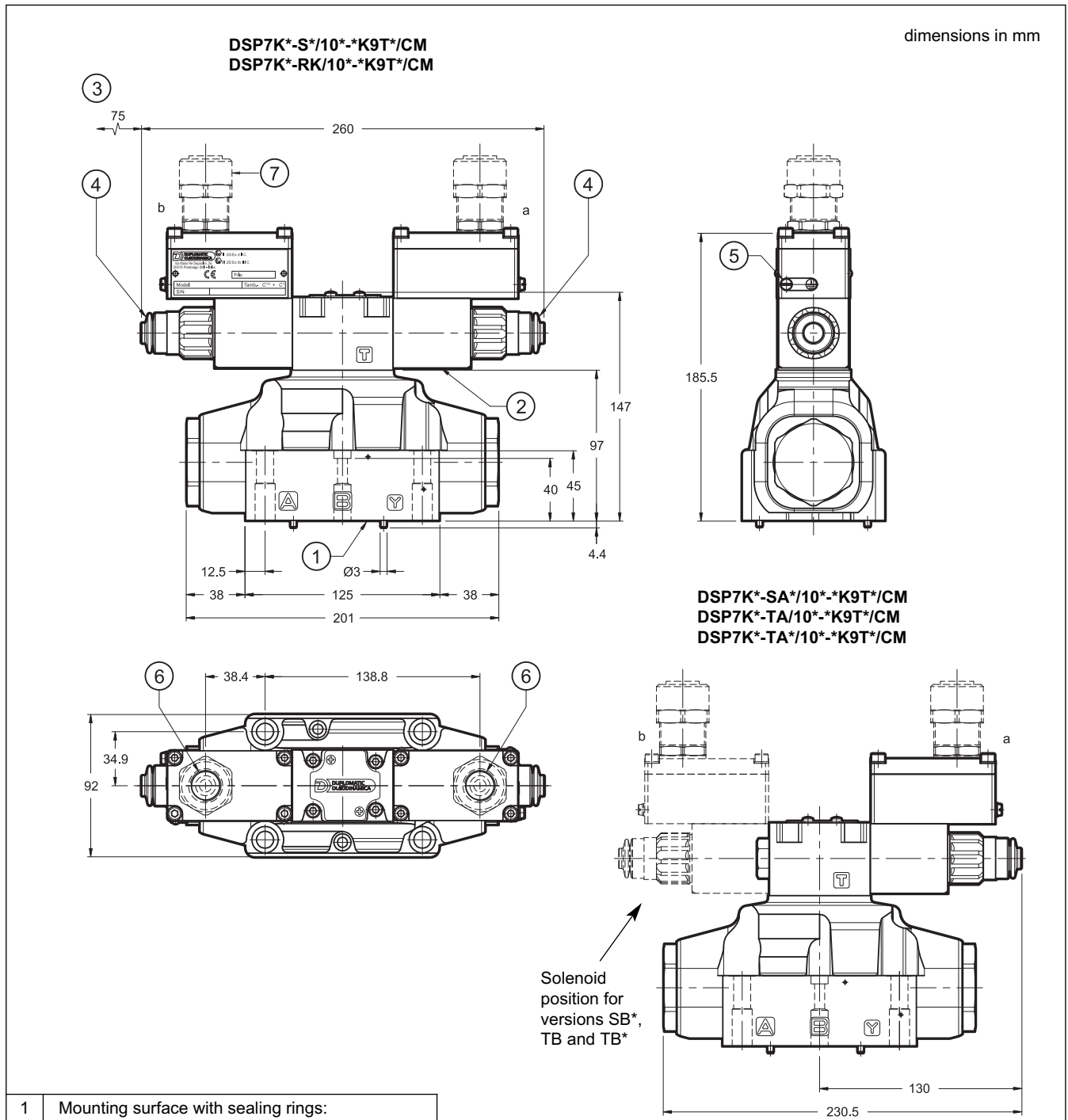
11 - DSP7K* OVERALL AND MOUNTING DIMENSIONS

1	Mounting surface with sealing rings: 4 OR type 130 (22.22X2.62) - 90 Shore 2 OR type 2043 (10.82x1.78) - 90 Shore
2	Explosion-proof coil
3	Minimum clear space required
4	Manual override, boot protected (standard for both N and V seals) - for blind ring nut dimensions (standard for NL seals) see par. 16
5	Terminal for supplementary GND connection
6	Upper port for cable gland
7	Cable gland. To be ordered separately, see paragraph 17

NOTE 1: for overall dimensions with Z option (fixed adjustment pressure reducing valve) consider an increase of 40 mm in height.

NOTE 2: for side port cable gland see paragraph 14.

NOTE 3: use of class 10.9 fastening screws is recommended for version H valves (high pressure).

Valve fastening: 4 SHC screws ISO 4762 M10x60 2 SHC screws ISO 4762 M6x50
Tightening torque: M10x60: 40 Nm (A8.8 screws) - 57 Nm (A10.9 screws) M6x50: 8 Nm (A8.8 screws) - 12 Nm (A10.9 screws)
Threads of mounting holes: M6x12; M10x18

12 - DSP8K* OVERALL AND MOUNTING DIMENSIONS

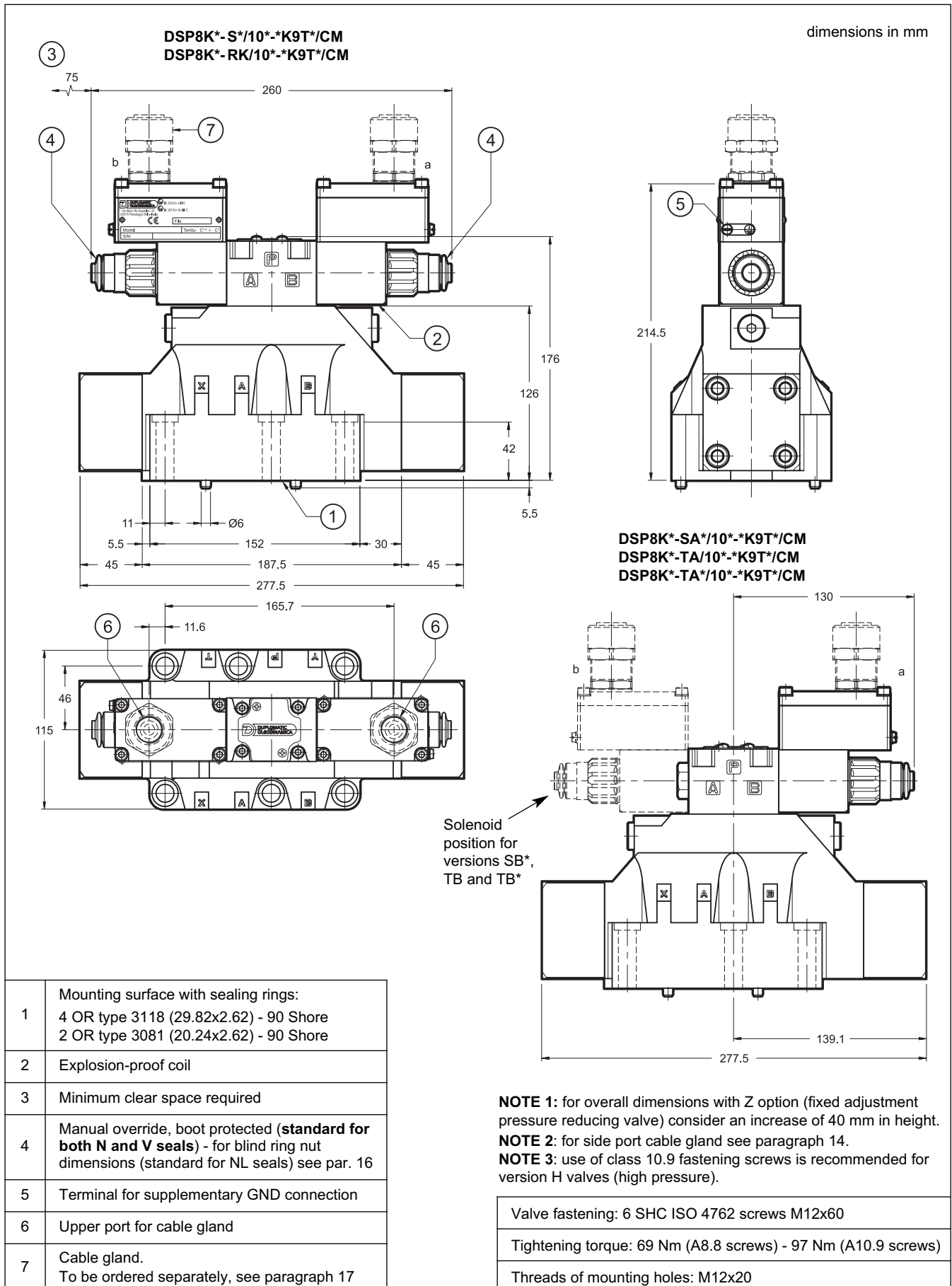

13 - DSP10K* OVERALL AND MOUNTING DIMENSIONS

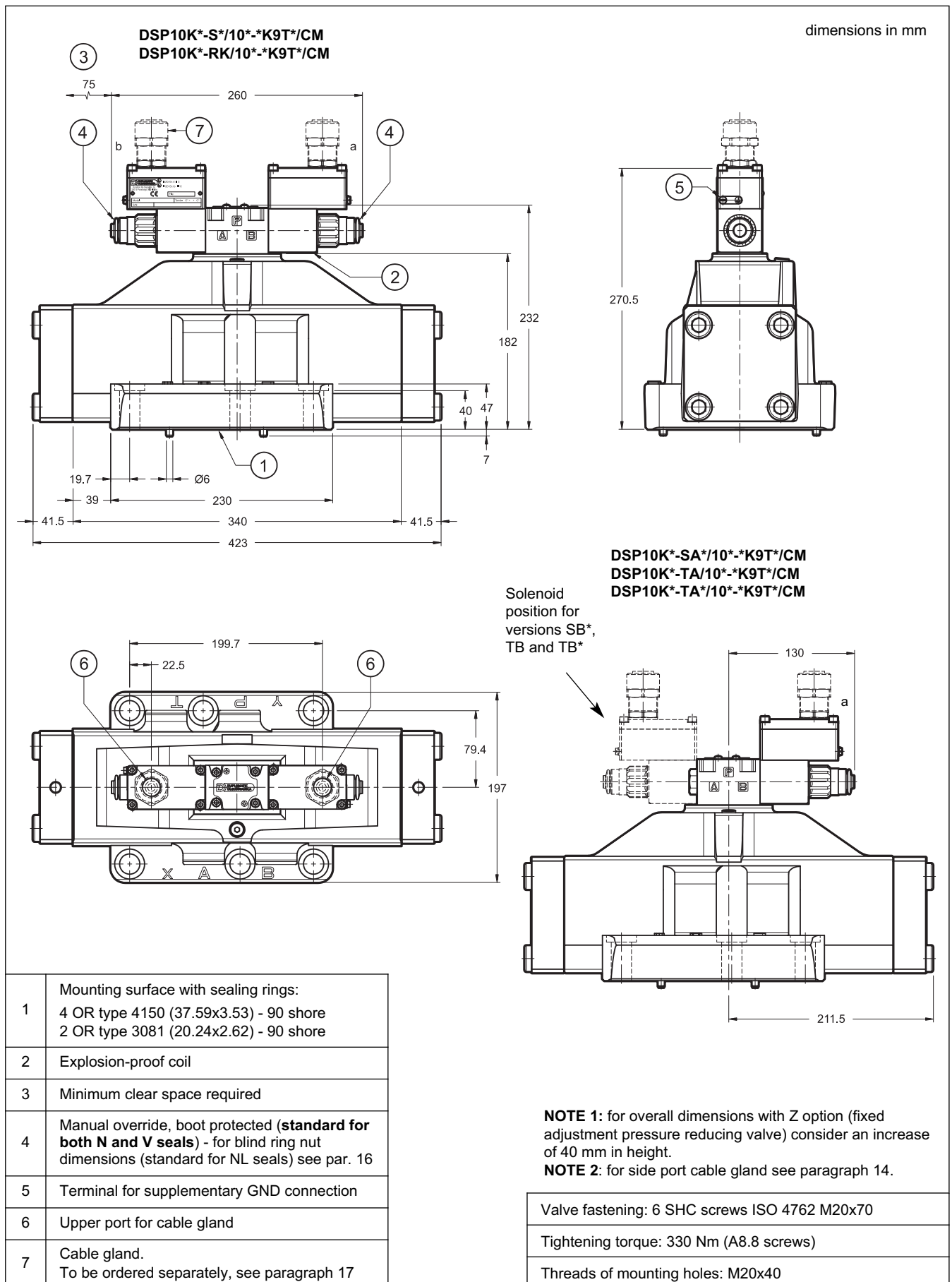

14 - DSP*K*/10*-K9S*/* (SIDE CONNECTION) OVERALL AND MOUNTING DIMENSIONS

DSP5K*/10*-K9S*/*
DSP5RK*/10*-K9S*/*

Side port type	A
S01, S04	150.5
S02, S03	150

DSP7K*/10*-K9S*/*

Side port type	A
S01, S04	157.5
S02, S03	157

dimensions in mm

DSP8K*/10*-K9S*/*

Side port type	A
S01, S04	186.5
S02, S03	186

Side port type	A
S01, S04	186.5
S02, S03	186

DSP10K*/10*-K9S*/*

Side port type	A
S01, S04	242.5
S02, S03	242

Side port type	A
S01, S04	242.5
S02, S03	242

8	Side port
9	Cable gland. To be ordered separately, see par. 17

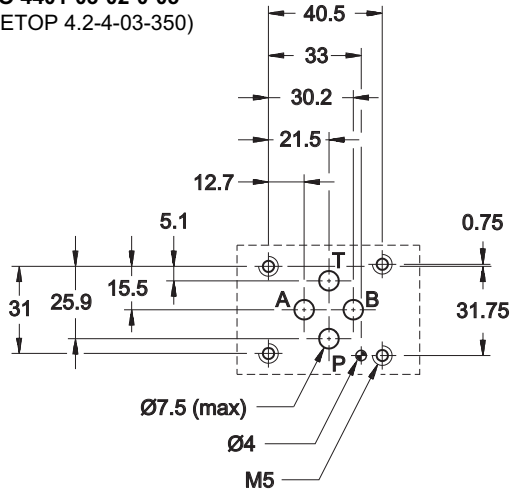
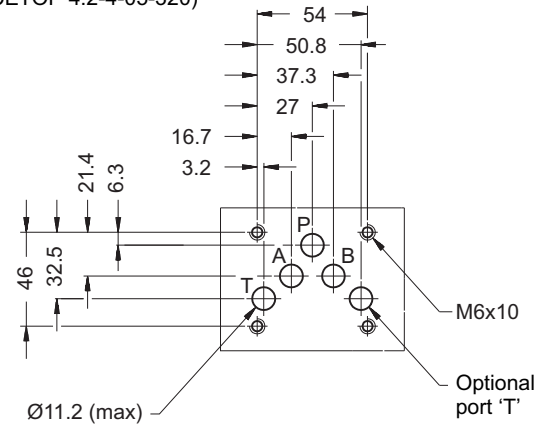
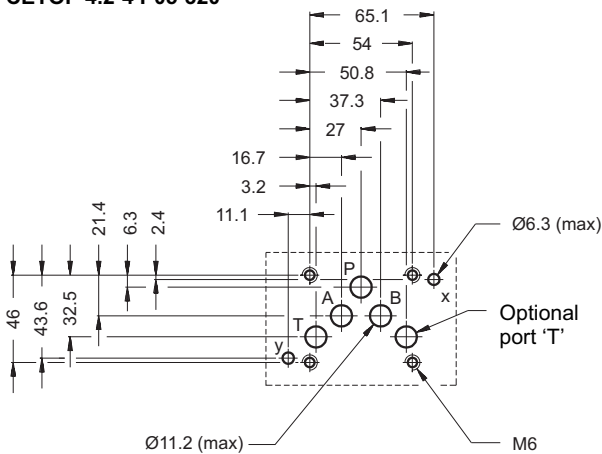
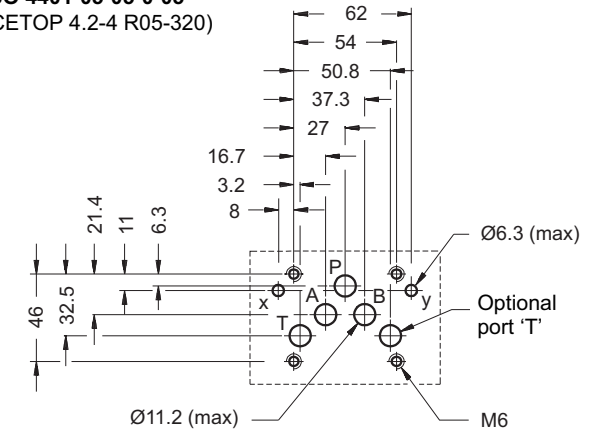
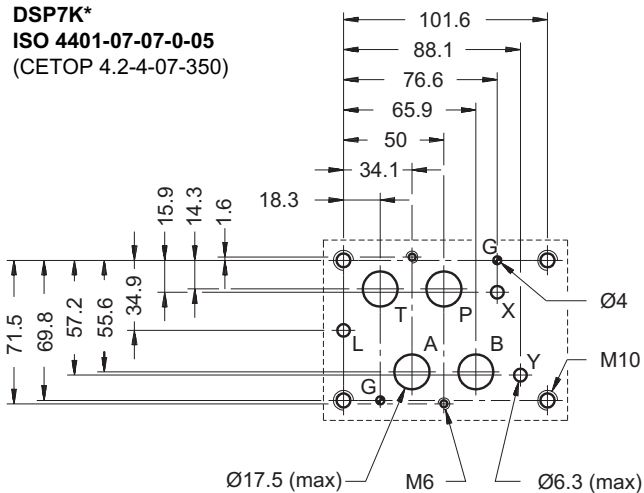
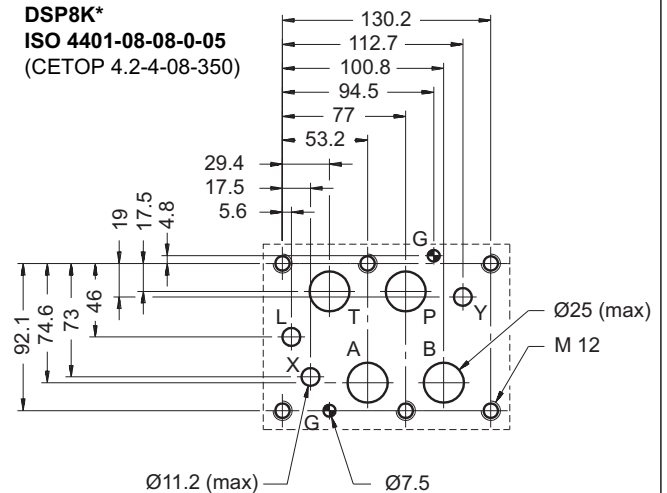
15 - MOUNTING SURFACES
DS3K*
ISO 4401-03-02-0-05
 (CETOP 4.2-4-03-350)

DL5BK*
ISO 4401-05-04-0-05
 (CETOP 4.2-4-05-320)

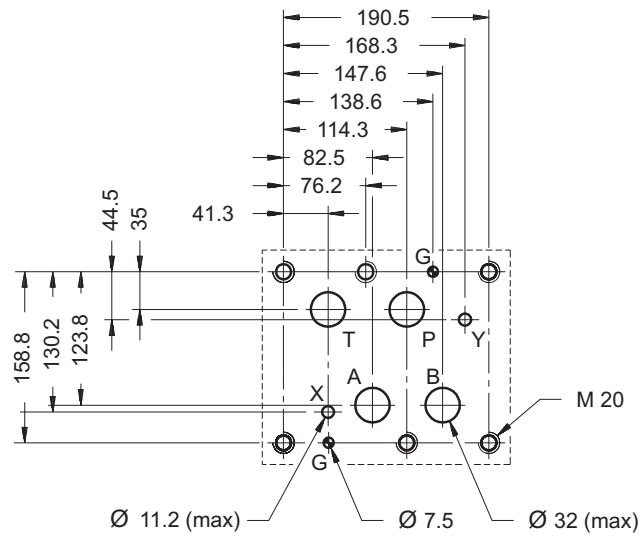
DSP5K*
CETOP 4.2-4 P05-320

DSP5RK*
ISO 4401-05-05-0-05
 (CETOP 4.2-4 R05-320)

DSP7K*
ISO 4401-07-07-0-05
 (CETOP 4.2-4-07-350)

DSP8K*
ISO 4401-08-08-0-05
 (CETOP 4.2-4-08-350)

DSP10K*
ISO 4401-10-09-0-05
(CETOP 4.2-4-10-350)



16 - MANUAL OVERRIDES

16.1 - CB - Blind ring nut

The metal ring nut protects the solenoid tube from atmospheric agents and isolates the manual override from accidental operations. The ring nut is tightened on a threaded fastener that keeps the coil in its position even without the ring nut.

To access the manual override loose the ring nut and remove it; then reassemble hand tightening, until it stops.

Activate the manual override always and only with non-sparking tools suitable for use in ATEX areas classified.

More information on safe use of ATEX classified components are provided in the instruction manual, always supplied with the valve.

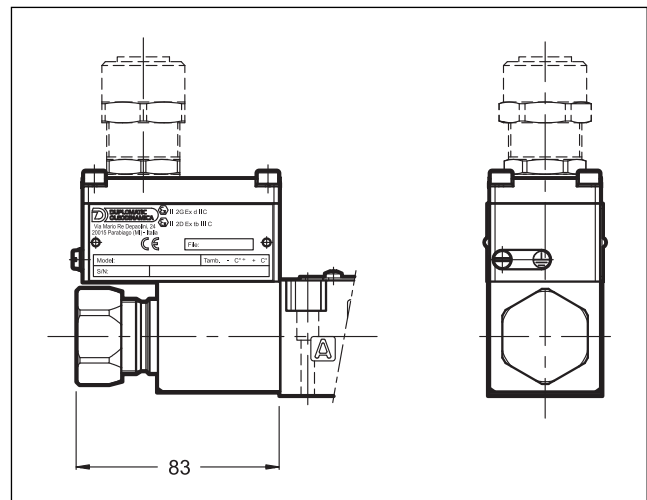

16.2 - CH - Lever manual override

The seals choice leads the type of the standard ring nut to be mounted.

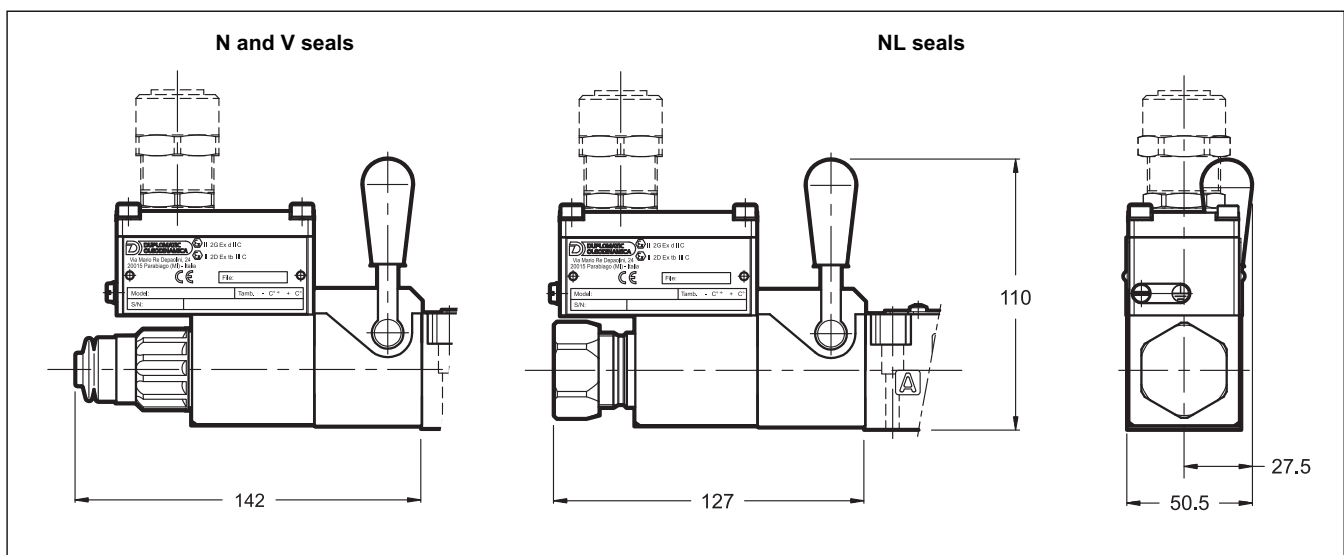

17 - CABLE GLANDS

Cable glands must be ordered separately; Duplomatic offers some types of cable glands with the following features:

- version for non-armoured cable, external seal on the cable (suitable for Ø8+10 mm cables);
- ATEX II 2GD and I M2 certified
- cable gland material: nickel brass
- rubber tip material: silicone
- ambient temperature range: -70 °C + +220 °C
- protection degree: IP66/IP68
- tightening torque: 15 Nm

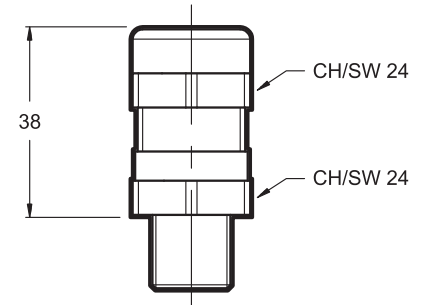

To order, list the description and the code of the version chosen from among those listed below:

Description: CGK2/NB-01/10

Code: 3908108001

M20x1.5 - ISO 261 male thread, suitable for coils with T01 and S01 connections. It is supplied equipped with silicone seal, that must be assembled between the cable gland and the coil, so as to ensure IP66/IP68 protection degree.

Description: CGK2/NB-03/10

Code: 3908108003

1/2" NPT - ANSI B1.20.1 (ex ANSI B2.1), suitable for coils with T03 and S03 connections. The customer must apply LOCTITE® 243™ threadlocker or similar between the cable gland connection thread and the coil in order to ensure IP66/IP68 protection degree.

Description: CGK2/NB-02/10

Code: 3908108002

Gk 1/2 - UNI EN 10226-2 male thread, suitable for coils with T02 and S02 connections. The customer must apply LOCTITE® 243™ threadlocker or similar between the cable gland connection thread and the coil in order to ensure IP66/IP68 protection degree.

Description: CGK2/NB-04/10

Code: 3908108004

M16x1.5 - ISO 261 male thread, suitable for coils with S04 connection. It is supplied equipped with silicone seal, that must be assembled between the cable gland and the coil, so as to ensure IP66/IP68 protection degree.

18 - HYDRAULIC FLUIDS

Use mineral oil-based hydraulic fluids HL or HM type, according to ISO 6743-4. For these fluids, use NBR seals (code N). For fluids HFDR type (phosphate esters) use FPM seals (code V). For the use of other fluid types such as HFA, HFB, HFC, please consult our technical department. Using fluids at temperatures higher than 80 °C causes a faster degradation of the fluid and of the seals characteristics. The fluid must be preserved in its physical and chemical characteristics.

19 - INSTALLATION



Installation must adhere to instructions reported in the *Use and Maintenance* manual, always attached to the valve. Unauthorized interventions can be harmful to people and goods because of the explosion hazards present in ATEX classified areas .

Configurations with centering and recall springs can be mounted in any position; The RK versions, without springs and with mechanical detent, must be mounted with the longitudinal axis horizontal.

Valve fastening takes place by means of screws or tie rods, laying the valve on a lapped surface, with values of planarity and smoothness that are equal to or better than those indicated in the drawing.

If the minimum values of planarity or smoothness are not met, fluid leakages between valve and mounting surface can easily occur.

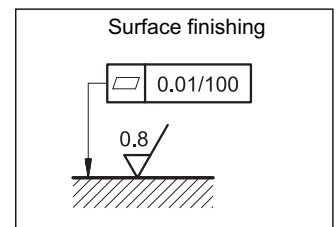



20 - SUBPLATES

(see catalogue 51 000)

	DS3K*	DL5BK*		DSP5K*	DSP7K*	DSP8K*
Type with rear ports	PMMD-AI3G	PMD4-AI4G	-	PME4-AI5G	PME07-AI6G	-
Type with side ports	PMMD-AL3G	-	PMD4-AL4G	PME4-AL5G	PME07-AL6G	PME5-AL8G
P, T, A, B ports dimensions	3/8" BSP	3/4" BSP	1/2" BSP	3/4" BSP	1" BSP	1 1/2" BSP
X, Y ports dimensions	-	-	-	1/4" BSP	1/4" BSP	1/4" BSP

NOTE: Subplates (to be ordered separately) do not contain neither aluminium nor magnesium at a higher rate than the value allowed by norms according to ATEX directive for categories II 2GD and I M2 .

The user must take care and make a complete assessment of the ignition risk, that can occur from the relative use in potentially explosive environments.



DIPLOMATIC OLEODINAMICA S.p.A.
20015 PARABIAGO (MI) • Via M. Re Depaolini 24
Tel. +39 0331.895.111
Fax +39 0331.895.339
www.diplomatic.com • e-mail: sales.exp@diplomatic.com